



## vicPURE handsfree Speech Enhancement Library

The **vicPURE handsfree** signal processing library provides excellent full-duplex speech quality for hands-free equipment.

Key component of the suite are acoustic echo cancellation techniques that continuously adapt to the acoustic environment and automatically eliminate unwanted echos.

Other powerful signal processing algorithms ensure high speech intelligibility, appropriate volume and optimum adaptation to transmission channel conditions or various device characteristics.

The patented algorithms meet the highest standards and can be customised to your application.

### PRODUCT FEATURES

- VDA-compliant, full-duplex acoustic echo cancellation (AEC) for comfortable hands-free communication
- Single-channel, automatic noise reduction (ANR) and complete library of speech enhancement algorithms
- Platform-independent, proven code of high portability for Windows, Linux, macOS, iOS, Android
- Available on ADSP Blackfin, SHARC; i.Mx6 and i.Mx8 (32 bit and 64 bit ARM); ARM Cortex-M4
- Graphical parameterisation and evaluation tools

### APPLICATIONS

- Hands-free kits for cars and commercial vehicles
- Communication between control stations and emergency vehicles
- Intercom / building communication
- Conference technology and professional audio
- Emergency call systems
- Passenger information systems

### FUNCTIONS

- Full-duplex echo canceller, available for different signal conditions from telephony to multimedia quality
- Appropriate for analogue and digital networks (integrated Line Echo Canceller LEC)
- Compatible to ITU-T Rec. P.340, G.161, G.164, G.165, VDA-conform and proven
- Adjustable echo tail length up to 128 ms, negligible residual echo
- Robust echo cancellation, also during double talk (no explicit double talk detector, no VAD)
- Reliable, continuous adaption and convergence even under rough noise conditions
- Interface for audio data up to 32 kHz, 16 Bit
- Integrated noise reduction for background noise (e.g. engine noise in a car, traffic, babble noise)

### COMPATIBILITY

- ANSI C with hardware abstraction layer
- Proven algorithms on various platforms
- Support of PCs with Windows, Linux, macOS, on request also sound API integration (Linux ALSA, Windows MME, Mac OS CoreAudio)
- Mobile devices (iOS, Android, embedded Linux)
- Various embedded platforms like ADSP Blackfin, SHARC; TI C6000 DSPs; OMAP; ARM; PowerPC; x86
- Full integration in VoIP: Hands-free library for vicMedia SIP Stack as well as pjsip / pjmedia available
- Delivery as:
  - Object code for specific DSP platforms
  - Shared or Static Library for WIN and Linux environments

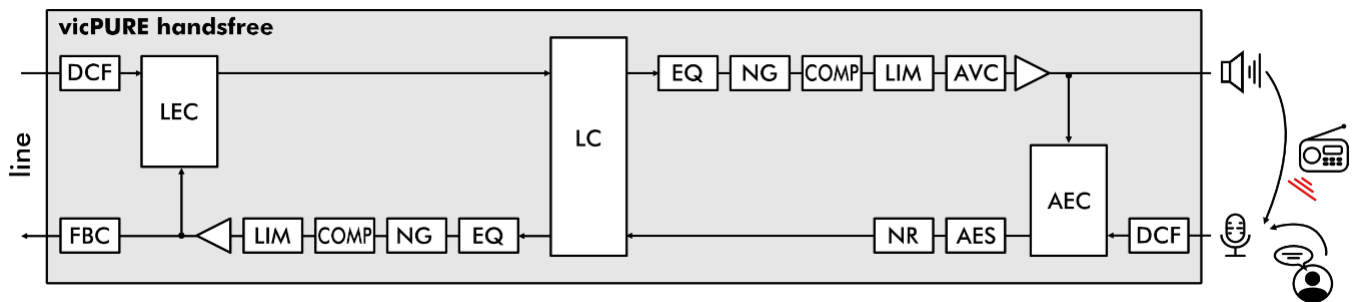

### KEY FEATURES ACCORDING TO VDA

- Echo cancellation in single talk (Terminal Coupling Loss):  $> 50$  dB (Requirement:  $> 46$  dB)
- Echo cancellation in double talk (Echo components / double Talk):  $> 27$  dB (Category 1 = full duplex)
- Adaption time not measurable in single talk (Echo level vs. time)
- Attenuation range in receiving direction, double talk:  $< 3$  dB (Category 1 = full-duplex)
- Attenuation range in sending direction, double talk:  $< 3$  dB

### COMFORT FEATURES

- Fully automatic modeling of echo path under different room conditions
- Comfortable API and parameter interface for integration of acoustic echo cancellation in your target application
- Extensive additional modules for application-specific adaption
- Comfort features: comfort noise, dynamic adaptation, equaliser, noise gate, feedback canceller

### RESOURCES REQUIREMENT

- Minimal memory consumption for data and program (e.g. 8 kHz, Blackfin DSP): 15 kB program memory, 20 kB data memory
- Low processor requirements (e.g. 8 kHz, Blackfin DSP): 20 MIPS

### FIND OUT MORE

info@voiceinterconnect.de  
Tel.: +49 351 407526 50